



# XC918-EV

ELECTRIC COMPACT WHEEL LOADER



**SOLID TO SUCCEED**



Operating Weight 6700kg

Bucket Capacity 1m<sup>3</sup>

Rated Power 58kW

Add:No. 99 Kumpeng North Road, Economic and Technological  
Development Zone, Xuzhou City, Jiangsu Prvindel  
Zip code:221122

Version:N202505V1



XCMG OFFICIAL WEBSITE



# MAIN SPECIFICATIONS

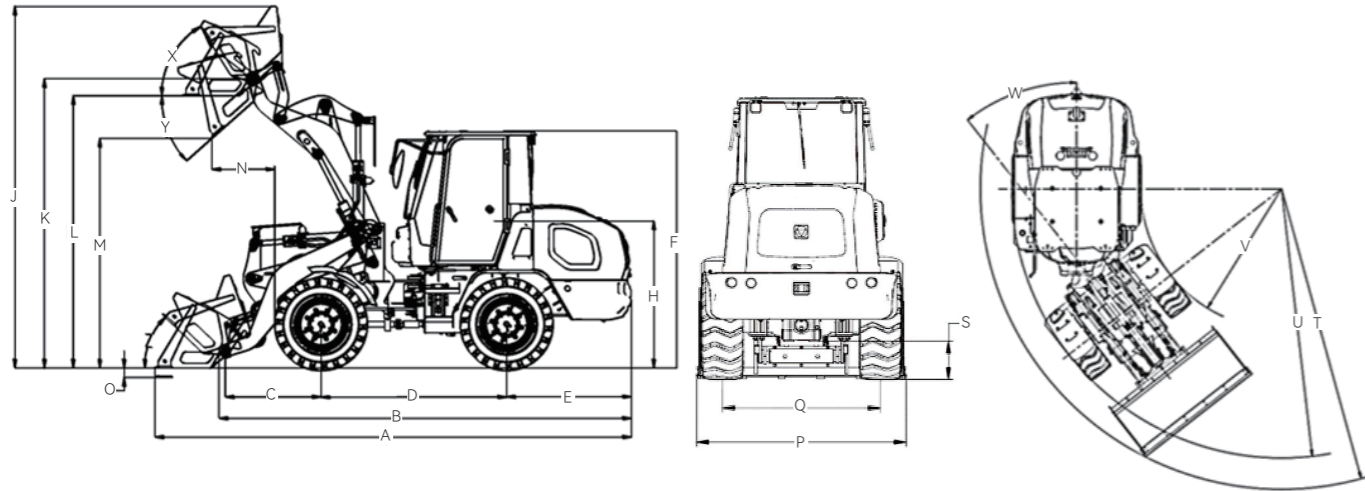

	Dimension and Specification	Parameter
A	Overall length	5670 mm
B	Overall length ( without bucket )	4773 mm
C	Distance: center of axle to bucket pin	1108 mm
D	Wheelbase	2150 mm
E	Length: rear axle to bumper	1370 mm
F	Overall height	2745 mm
H	Seat height (ground)	1660 mm
J	Max. operating height	4193 mm
K	Height to hinge pin, fully raised	3354 mm
L	Height: bucket leveling	3155 mm
M	Dumping height	2670 mm
N	Dumping reach	723 mm
O	Digging depth	90 mm
P	Overall width	2060 mm
Q	Wheel track	1550 mm
S	Ground clearance	350 mm
T	Turning radius: over bucket	4602 mm
U	Turning radius: outside of tyre	4123 mm
V	Turning radius: inside of tyre	2163 mm
W	Steering angle	38°
X	Rollback angle at full lift	58°
Y	Dumping angle at full lift	42°
Z	Rollback angle, ground	43.7°

Category	Item	Parameter	
Overall Parameter	Operating Weight	6700 kg	
	Bucket Capacity	1.0 m <sup>3</sup>	
	Rated Load	1800 kg	
	Max. Breakout Force	58 kN	
	Tipping Load	4745 kg 3888 kg	
Battery&Motor	Overall Voltage	310 /328 V	
	Max. Rated Output Power	58 kW	
	Max. Rated Output Torque	250 N · m	
	Max. Output Torque	680 N · m	
	Battery	LFP Battery	
	Battery Voltage	310 /328 V	
	Battery Capacity	70kWh (optional 100 kWh )	
	DC Charging Power	60 kW	
	AC Charging Power	11 kW	
	Electrical System Voltage (Low)	12 V	
	Low Voltage Battery Capacity	120 Ah	
	Charging Time	70 kWh	60 kW-70 min
			11 kW-390 min
Charging Time	100 kWh	60 kW -100 min	
		11 kW-540 min	
Working Hydraulic System	Type	Constant pressure hydraulic system, standard third function	
	Pump	Duplex gear pump	
	Rated Flow	70 L/min	
	Control Valve	Third function multiway valve	
	System Pressure	24 MPa	
	Total Circle Time	10.5 s	
Axle	Type	Wet drive axle	
	Front/Rear Axle	Fixed	
	Reduction Gear	Planetary final drive	
	Differential	Front axle conventional differential/Rear axle limited-slip differential	

- The technology of XCMG wheel loaders is subject to constant improvement and upgrading. In case the specifications or detailed appearance contained in this brochure differ from actual products, the latter shall prevail.
- XCMG reserves the right of final interpretation for the above. Our products may be modified without prior notice to users.